

PRESSURE REDUCING VALVE RP45 (ASME)

DESCRIPTION

The ADCA RP45 series pressure reducing valves are single seated, bellows sealed controllers that operate without auxiliary energy. Designed for use with steam, compressed air, and other gases compatible with the construction.

They are particularly suitable for reducing steam pressure in all energy and process systems where pressures must be kept under control.

MAIN FEATURES

Specially designed high durability bellows, providing pressure balancing and frictionless plug stem.

Robust construction (fit-and-forget).

Suitable for use with high pressure turndowns.

Interchangeable actuators.

OPTIONS: Soft sealing version in PTFE/GR for use with steam.
Nitrile rubber soft sealing version for air and gas applications, where tight shut-off is required.
Low-noise flow divider.

USE: Steam, compressed air and other gases compatible with the construction. Limited use with liquids. Consult manufacturer before installing the valve with liquids.

AVAILABLE MODELS: RP45S and RP45ST or N – cast steel.
Suffix T: soft sealed with PTFE/GR.
Suffix N: soft sealed with nitrile rubber.

SIZES: 1/2" to 4".

CONNECTIONS: Flanged ASME B16.5 Class 150 or 300.

AVAILABLE ACTUATORS: A1, A10, A11, A12, A3, A4 – carbon steel.
A2, A21 – SG iron or carbon steel.

INSTALLATION: See IMI – Installation and maintenance instructions.



CE MARKING – GROUP 2 (PED – European Directive)		
Class 150	Class 300	Category
1/2" to 2"	1/2" to 1"	SEP
3" to 4"	1 1/2" to 4"	1 (CE marked)

LIMITING CONDITIONS

Valve model	RP45S	RP45S	RP45ST	RP45ST	RP45SN	RP45SN
Body design conditions	Class 150	Class 300	Class 150	Class 300	Class 150	Class 300
Maximum upstream pressure	13 bar	25 bar	13 bar	25 bar	13 bar	25 bar
Maximum downstream pressure	13 bar	18 bar	13 bar	18 bar	13 bar	18 bar
Minimum downstream pressure	0,15 bar	0,15 bar	0,15 bar	0,15 bar	0,15 bar	0,15 bar
Maximum operating temperature	200 °C	250 °C	200 °C	200 °C	80 °C	80 °C
Maximum reducing ratio	25:1	25:1	25:1	25:1	10:1	10:1
Rangeability	10:1	10:1	10:1	10:1	10:1	10:1
Maximum hydraulic factory valve body test	24 bar	60 bar	24 bar	60 bar	24 bar	60 bar

Remark: Other soft materials and temperature limits on request.

Actuator model	A1 A1i	A10 A10i	A11 A11i	A12 A12i	A2 A2i	A21 A21i	A3 A3i	A4 A4i
Maximum operating pressure (bar)	25	25	25	25	12	18	2,5	1,5
Maximum operating temperature	90 °C *							

* The water seal pot must be installed in the sensing pipe when operating with steam or liquids at temperatures above 90 °C.

FLOW RATE COEFFICIENTS (m³/h)

SIZE	1/2"	3/4"	1"	1 1/2"	2"	3"	4"
Kvs	4,8	6,9	9,1	14,4	26,5	79,5	129,5

SATURATED STEAM CAPACITY TABLE (kg/h)

INLET (barg)	SIZE						
	1/2"	3/4"	1"	1 1/2"	2"	3"	4"
0,5	51	68	90	186	300	800	1250
0,75	63	84	112	230	360	1000	1550
1	75	100	133	280	430	1200	1850
1,5	100	133	175	360	590	1600	2500
2	126	170	230	450	730	2000	3050
2,5	150	200	260	550	880	2400	3600
3	175	240	310	640	1010	2700	4300
4	220	290	390	800	1300	3400	5400
5	260	350	480	1000	1600	4200	6500
6	330	440	580	1220	1930	5100	8000
7	400	520	700	1430	2300	6100	9500
8	450	600	800	1670	2700	7100	11000
9	500	670	880	1800	2900	7800	12000
10	560	750	980	2000	3200	8500	13500
12	680	900	1180	2500	4000	10500	16300
14	800	1050	1400	2900	4700	12600	19000
16	920	1230	1630	3400	5500	14600	22000
18	1040	1400	1860	3800	6200	16600	25000
20	1170	1540	2100	4200	7000	18600	28000
22	1330	1780	2350	4900	7800	21000	32000
24	1500	2000	2600	5400	8700	23500	36000
25	1600	2150	2800	5700	9200	25500	38000

Remark: For pressure ratios where $P2 > 0,7 P1$ and/or when the operating medium is superheated steam, a correction factor must be applied. See next page.

CORRECTION FACTORS

Pressure ratio:

The capacities given in the "Saturated steam capacity table" are applicable in scenarios where $P_2 < 0,7 P_1$.

In the remaining scenarios a correction factor must be applied:

PRESSURE RATIO * P2 / P1	CORRECTION FACTOR f
≥ 0,7	1,25
≥ 0,8	1,6
≥ 0,9	2,25

* Pressure ratio in bar abs (barg + 1)

Superheated steam:

When the medium is superheated steam, instead of saturated steam, a correction factor must also to be applied. The required mass flow must be multiplied by the following factor:

$\frac{V_h}{V_s}$, where V_h = specific volume of superheated steam, and
 V_s = specific volume of saturated steam.

ACTUATOR AND SPRING SELECTION TABLE

SIZE	ACTUATOR										
		A4		A3	A2	A21	A1		A10	A11	A12
1/2"	Spring range (bar)	0,15-0,49	0,5-0,99	1,0-1,6	1,7-3,8	3,9-5,5	5,6-8,2	–	–	8,3-13	10-18
	Spring N°	66	60	60	60	60	60	–	–	60	60.1
3/4"	Spring range (bar)	0,15-0,49	0,5-0,99	1,0-1,6	1,7-3,8	3,9-5,5	5,6-8,2	–	–	8,3-13	10-18
	Spring N°	66	60	60	60	60	60	–	–	60	60.1
1"	Spring range (bar)	0,15-0,49	0,5-0,99	1,0-1,6	1,7-3,8	3,9-5,5	5,6-8,2	–	–	8,3-13	10-18
	Spring N°	66	60	60	60	60	60	–	–	60	60.1
1 1/2"	Spring range (bar)	0,15-0,49	0,5-0,99	1,0-1,6	1,7-3,8	3,9-5,5	5,6-8,2	–	–	8,3-13	10-18
	Spring N°	66	60	60	60	60	60	–	–	60	60.1
2"	Spring range (bar)	0,15-0,49	0,5-0,99	1,0-1,9	2,0-4,2	4,3-6,9	7-8,5	–	10-18	8,6-13	–
	Spring N°	67	61	61	61	61	64	–	61	64	–
3"	Spring range (bar)	0,15-0,45	0,46-0,99	1,0-1,9	2,0-5,0	5,1-8,9	9-13	11-18	–	–	–
	Spring N°	68	62	62	62	62	65	62	–	–	–
4"	Spring range (bar)	0,15-0,45	0,46-0,99	1,0-1,9	2,0-6,0	6,1-13,0	–	11-18	–	–	–
	Spring N°	69	63	63	63	63	–	63	–	–	–

HOW TO SIZE (USING STEAM TABLE)

Example:

Required saturated steam capacity: 500 kg/h; Upstream pressure: 3 bar; Required downstream pressure: 2 bar.

Solution:

First determine correction factor for pressure ratio: $(2+1) / (3+1) = 0.75 \rightarrow f=1.25$,

Then multiply the given capacity: $500 \times 1,25 = 625 \text{ kg/h}$

Afterwards, refer to the cell with the number "3" in the column "INLET" of the saturated steam capacity table. In that line, the values for selection of the pressure reducing valve size can be found. In this particular scenario, a value equal to or higher than 625 kg/h is required, and the right selection would be 1 1/2", with a capacity of 640 kg/h.

On the actuator and spring selection table, for a downstream pressure of 2 bar, the recommended actuator is the A2, and the regulating spring is N° 60.

Remarks: Never size the valve according to the pipe diameter in which it has to be fitted, but according to the actual flow required. Pipe sizing must also respect the maximum recommended flow velocities, according to the medium.

HOW TO SIZE (USING Kvs)

Please consult formulas on IS PV10.00 E or consult manufacturer.

HOW TO ORDER

RP45S 1 1/2" Class 150 valve complete with spring N° 60, A2 actuator, condensate vessel and copper sensing pipe.

INSTALLATION

Horizontal installation with the actuator vertically, pointing downwards.

Installation with the actuator pointing upwards is possible only when the medium temperature is below 90 °C.

The sensing pipe, if not fitted on the valve body, must be installed downstream of the valve at a minimum of 1 meter away or 15 pipe diameters.

In steam applications, a "Y" strainer, humidity separator and steam trap should be installed upstream of the valve.

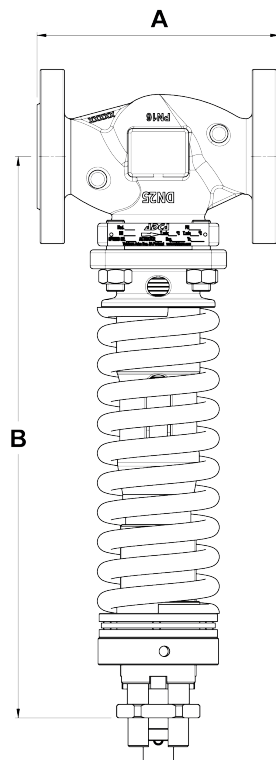

DIMENSIONS – VALVE (mm)

DIMENSION		SIZE						
		1/2"	3/4"	1"	1 1/2"	2"	3"	4"
A		190	194	197	235	267	317	368
B		366	366	371	384	470	556	597
WEIGHT (kg)	CLASS 150	8,9	9,2	11,2	15	22,1	45,5	58,6
	CLASS 300	9,3	10,2	11,8	16,8	22,8	47,5	62,9

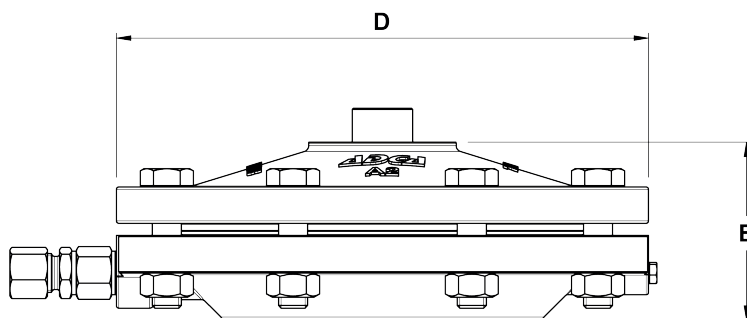

DIMENSIONS – ACTUATOR (mm)

DIMENSION	ACTUATOR							
	A1	A10	A11	A12	A2	A21	A3	A4
D	172	172	172	172	220	220	282	340
E	67	67	67	67	74	74	71	81
WEIGHT (kg)	4,3	4,3	4,3	4,3	7,3	7,3	11,3	16,3

MATERIALS

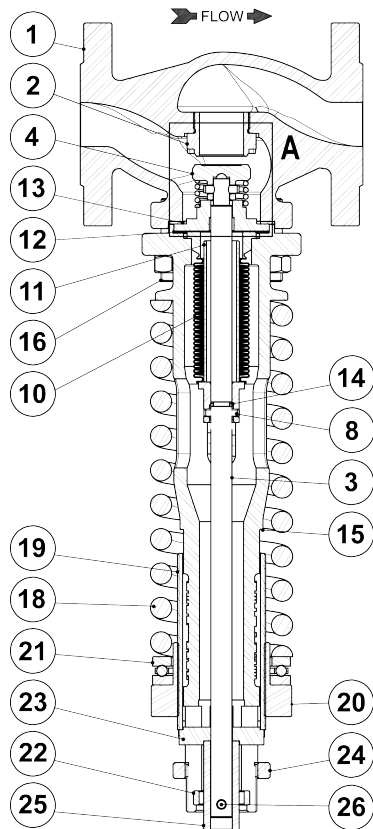

1/2" to 2"

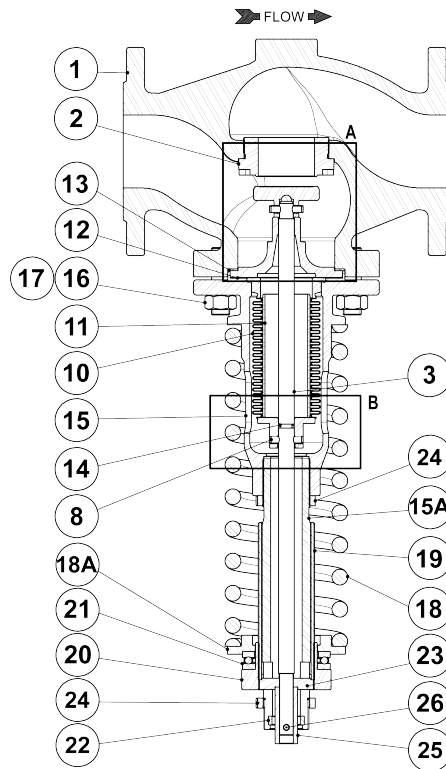

2 1/2" to 4"

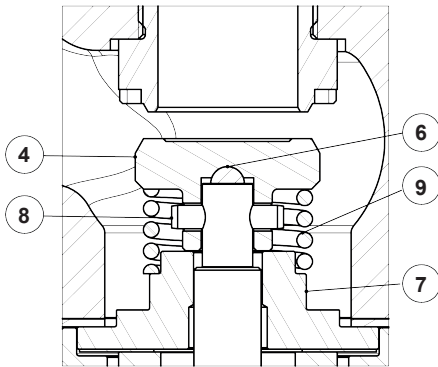

Detail A
 (1/2" to 1 1/2")

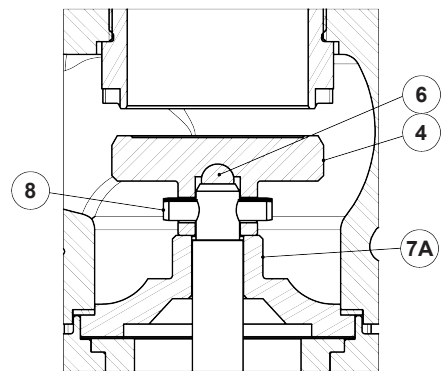

Detail A
 (2" to 2 1/2")

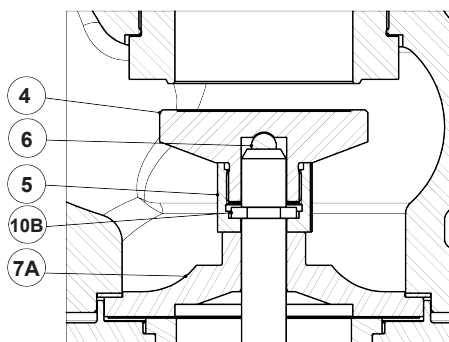

Detail A
 (3" to 4")

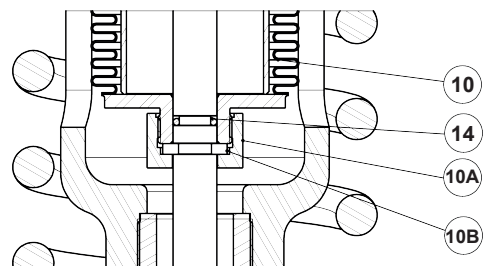

Detail B
 (3" tp 4")

MATERIALS – VALVE

POS. N°	DESIGNATION	MATERIAL
1	Valve body	A216 WCB / 1.0619
2	Seat	AISI 316 / 4.4401
3	Stem	AISI 304 / 1.4301
4	* Valve plug	AISI 420 / 1.4021
5	Nut	AISI 316 / 1.4401
6	Ball	AISI 440C / 1.4125
7	Stem guide	AISI 304 / 1.4301
7A	Stem guide	Bronze
8	Pin	AISI 301 / 1.4310
9	Compensating spring	AISI 302 / 1.4300
10	* Bellows	AISI 316Ti / 1.4571
10A	Nut	AISI 316 / 1.4401
10B	Split ring	AISI 316 / 1.4401
11	Guide tube	CuZn39Pb3
12	Bellows gasket	Stainless steel / Graphite
13	Body gasket	Stainless steel / Graphite
14	O-ring	EPDM
15	Piston body	A216 WCB / 1.0619
15A	Piston body extension	P355Ti / 1.0421
16	Studs	34CrNiMo6 / 1.6582
17	Nuts	Zinc plated steel
18	* Adjustment spring	Spring steel
18A	Lower spring plate	C45E / 1.1191
19	Threaded tube	CuZn39Pb3
20	Spring adjusting nut	C45E / 1.1191
21	Ball bearing	Zinc plated steel
22	Spacer	S355J2G3 / 1.0570
23	Pressure star	S235JR / 1.0038
24	Lock nut	C45E / 1.1191
25	Pressure tube	C45E / 1.1191
26	Pin	AISI 303 / 1.4305

* Available spare parts.

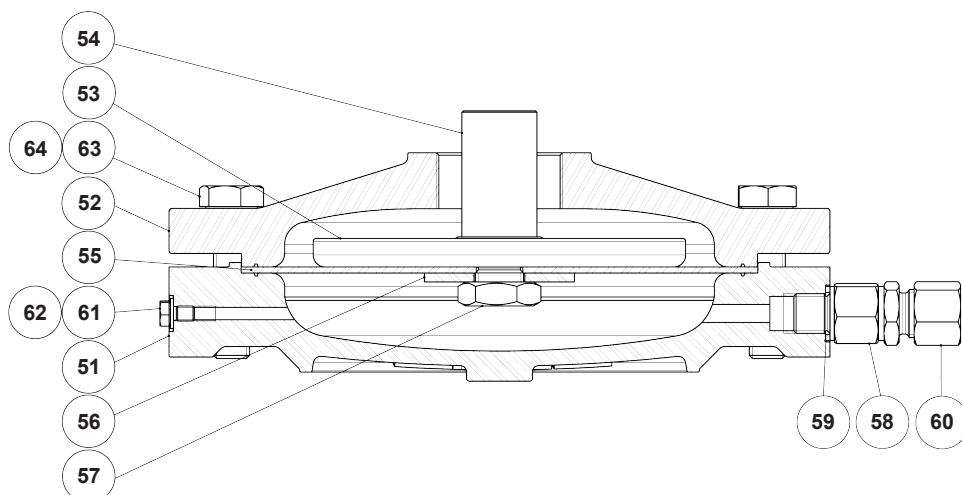

MATERIALS – ACTUATOR

POS. N°	DESIGNATION	A1 / A11 / / A3 / A4	A2 / A21
51	Lower diaphragm chamber	A216 WCB / 1.0619	GJS-400-15 / 0.7040; A216 WCB / 1.0619
52	Upper diaphragm chamber	A216 WCB / 1.0619	GJS-400-15 / 0.7040; A216 WCB / 1.0619
53	Pressure plate	GJS-400-15 / 0.7040	GJS-400-15 / 0.7040
54	Diaphragm plate spindle	GJS-400-15 / 0.7040	GJS-400-15 / 0.7040
55	Diaphragm	Neoprene reinforced polyamid	Neoprene reinforced polyamid
56	Washer	Copper	Copper
57	Hex nut	CuZn39Pb3	CuZn39Pb3
58	Flow restrictor	AISI 303 / 1.4305	AISI 303 / 1.4305
59	Gasket	Copper	Copper
60	Compression fitting	AISI 316Ti / 1.4571	AISI 316Ti / 1.4571
61	Bolts	Zinc plated steel	Zinc plated steel
62	Washer	Copper	Copper
63	Bolts	Zinc plated steel	Zinc plated steel
64	Nuts	Zinc plated steel	Zinc plated steel